



Soundproofing America Online Store Your #1 Soundproofing Source Worldwide

Toll Free Line: **877-530-0139**

West Coast Number: **760-510-9189**

East Coast Number: **347-328-0501**

Fax: **760-571-5007**



TruAcoustics™ Interior Windows

Engineered to be the markets first affordable
high performance acoustical window

- A truly affordable high performance noise control window.
- Performance tested & certified at an affordable price.
- STC Ratings of 45 to 56.
- Custom engineered and manufactured to any size at no extra charge.
- Fits wall assemblies from 4-1/2" in thickness and greater.
- Anodized aluminum frames with standard frame finishes of natural aluminum and bronze. Also available in other specialty finishes.
- Quick turnaround delivery upon order!
- Easy Installation. No need for a glazing contractor or special tools required. SoundProofing America includes installation instructions, necessary shop drawings, and certification of test results upon request.
- Tested and certified options of STC-45 and STC-56 windows.
- Fast and easy do it yourself installation
- Custom glass available (safety glass, argon, tinted and etc.) Note: using custom glass may change the STC value.
- **Note:** Glass shipped separately to avoid breakage, easy clip in glass installation at job site.



Soundproofing America Online Store Your #1 Soundproofing Source Worldwide

Toll Free Line: **877-530-0139**

West Coast Number: **760-510-9189**

East Coast Number: **347-328-0501**

Fax: **760-571-5007**

TruAcoustics™ Interior Windows

Features:

- 4° angled glass for max acoustical performance.
- STC rating of 45
- Custom sizes
- Min size of 2' by 2'
- Max size of 4' by 8' rectangle or 5' by 5' square clear opening
- Larger units available with mullions
- Optional tinted, argon, safety glass and etc.

Window Specifications:

- One insulated glass unit with 2 pieces of 1/4" laminated glass.
- Angled glass for maximum acoustical performance
- Acoustically treated frames and seals
- Class A-1 ASTM E-84 Nonflammable Silent Panel™ acoustical frame insert
- Fits any wall thickness of 4.5" by inseting or offsetting acoustical window

TruAcoustics™ Interior Windows

Features:

- STC rating of 56
- Custom sizes
- Min size of 2' by 2'
- Max size of 4' by 8' rectangle or 5' by 5' square clear opening
- Larger units available with mullions
- Optional tinted, argon, safety glass and etc.

Window Specifications:

- One insulated glass unit with 2 pieces of 1/4" laminated glass plus an air cavity and an additional pane of 1/4" laminated glass.
- Acoustically treated frames and seals
- Angled and flat glass for maximum acoustical performance
- Class A-1 ASTM E-84 Nonflammable Silent Panel™ acoustical frame insert
- Fits any wall thickness of 6.5" by inseting or offsetting acoustical window

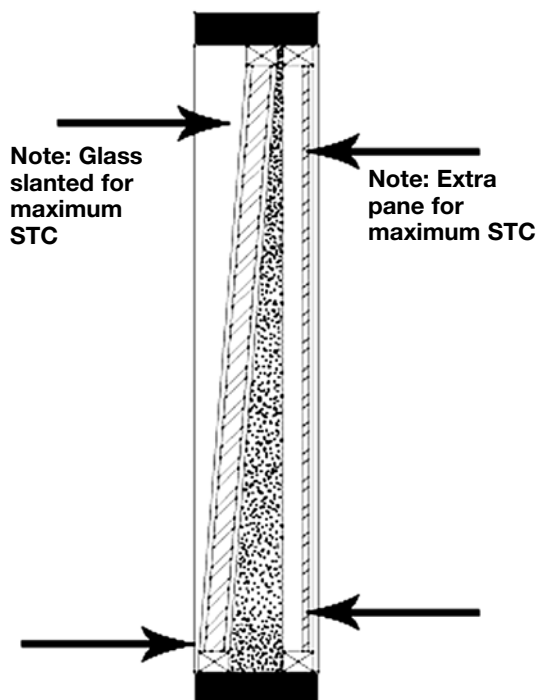

Continued on next page...



Soundproofing America Online Store
Your #1 Soundproofing Source Worldwide

Toll Free Line: **877-530-0139**

West Coast Number: **760-510-9189**

East Coast Number: **347-328-0501**

Fax: **760-571-5007**

TruAcoustics™ Interior Acoustic Window Section Details

TruAcoustics™ Interior Windows

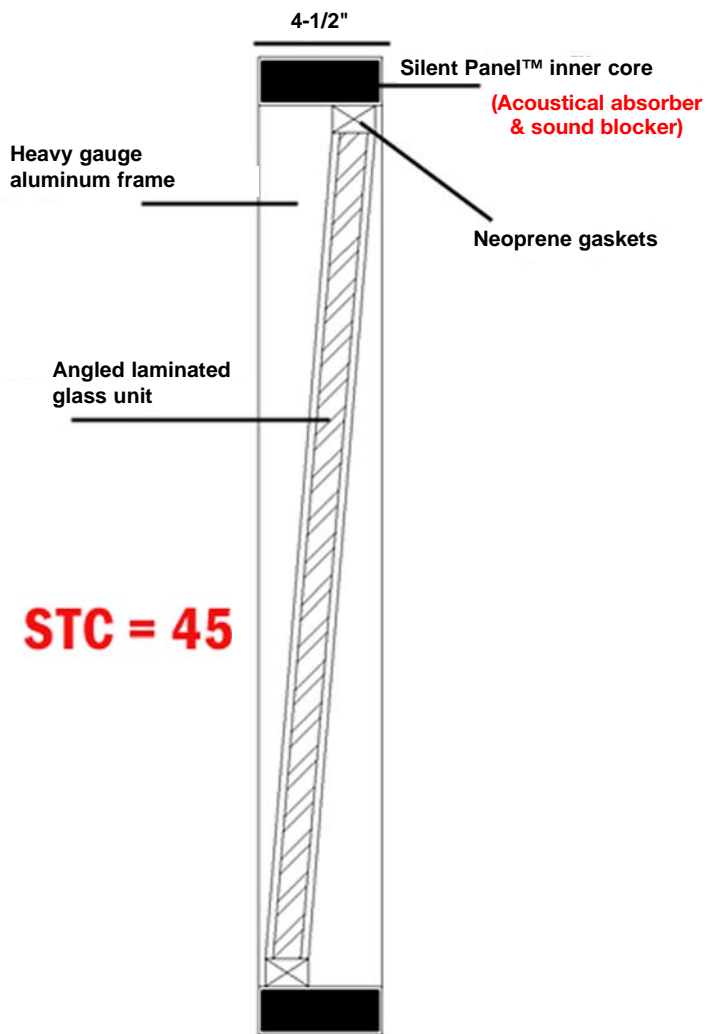

TruAcoustics™ Interior Windows

